

V901

PLUNGER / NEEDLE VALVE



Product Description

V901 Plunger Valve is the correct valve to use whenever pressure heads or flow rates need to be safely and reliably reduced and controlled. The flow regulation is done via the axial movement of a piston, operated by a rod and crank mechanism. To be able to control the pressure and flow precisely and finely, the valve's flow control characteristics must be as linear as possible over the whole opening range. This forms the core design criteria of V901 Plunger (Needle) Valves.

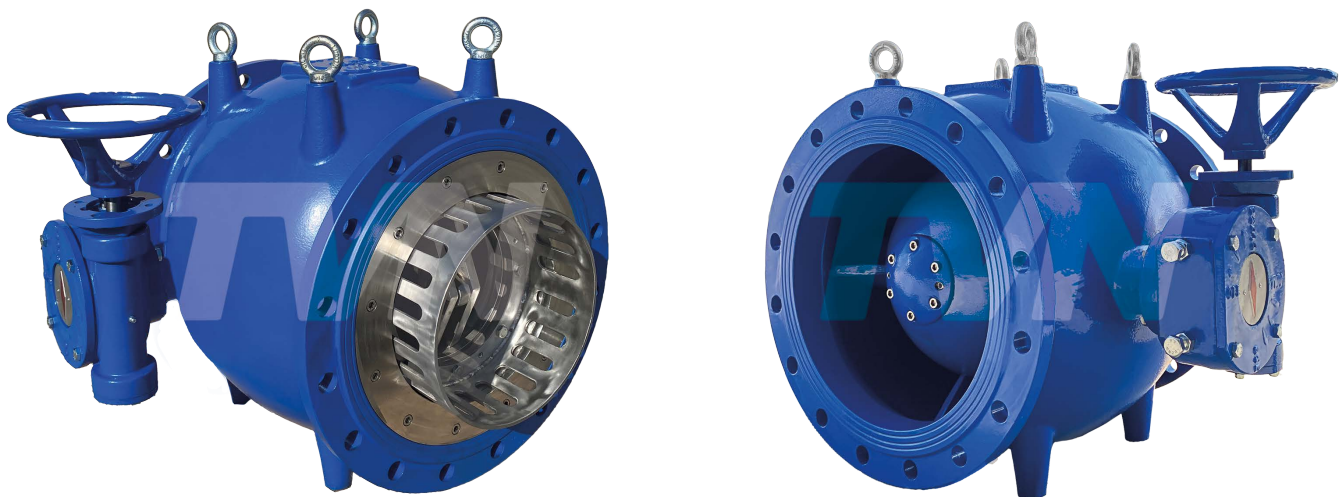

Technical Data

Size range	DN150 - DN1400
Pressure range	PN 10 - 16 - 25 - 40 - 64
Temperature	-10°C to +100 °C
Design	EN 593
Face to face	EN 558 Series 15
Flange drilling	EN 1092-2 / ISO 7005-2
Coating	Electrostatic Powder Epoxy
Testing	EN 12266-1
Marking	EN 19
Operation	Gearbox with Handwheel
	Electrical Actuators

Application Range

- Pumping Stations
- Reservoir and Turbine Inlet
- Shut off valve for high pressure and high flow velocity
- Bottom Outlet Valve for Dams
- Turbine by-pass
- Pressure Control and Flow Regulation

Related Products

- V106 Butterfly Valve Series 14
- V151 Gate Valve
- V202/203 Check Valve Tilting Type with Lever & Weight / With Hydraulic Damper
- V251 Dismantling Joint Full Tie Rod



POTABLE WATER

Product Features

- High corrosion resistant internal materials
- Lower torques at high pressure rates
- Suitable for flow adjustment
- A ring shaped symmetrical cross section that enables a linear control curve over the entire control range
- The piston's linear movement results from conversion of the rotary movement of the actuator shaft by the internal slider crank mechanism and ensures a well defined ring-shaped cross- section in every position
- Flow streams do not hit each other until they reach the middle of the valve or pipe, which reliably prevents cavitation damage to the valve
- Provides a ring-shaped cross-section in every piston position
- Reliable energy conversion in the middle of the flow stream, which significantly minimises any effects of cavitation
- Butterfly and gate valves, due to their design as isolation or shut-off valves are not suitable for continuous use as a variable flow control valve, with the unique design properties V901 Plunger Valves are able to control the flow continuously
- Through the Computerised Fluid Dynamics (CFD), a very high efficient and optimised plunger valves is designed
- Controls energy conversion from inlet to outlet
- The piston is positioned in the center of the valve body and operates in a chamber precisely shaped in order to avoid noises and cavitation damages
- For proper installation 10 X DN distance of a pipe length should be considered



V901 PLUNGER / NEEDLE VALVE



Variations

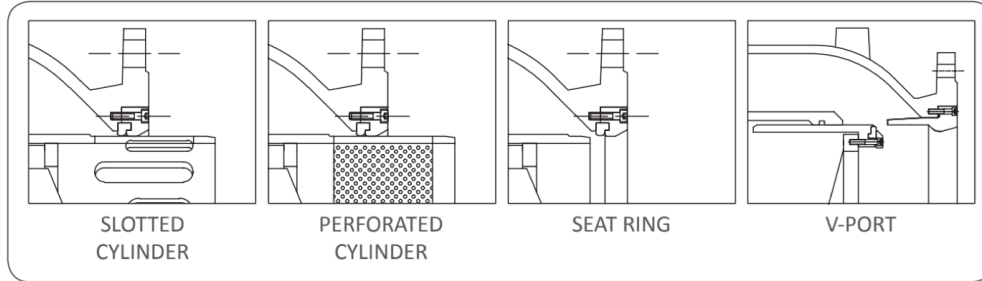

Material List

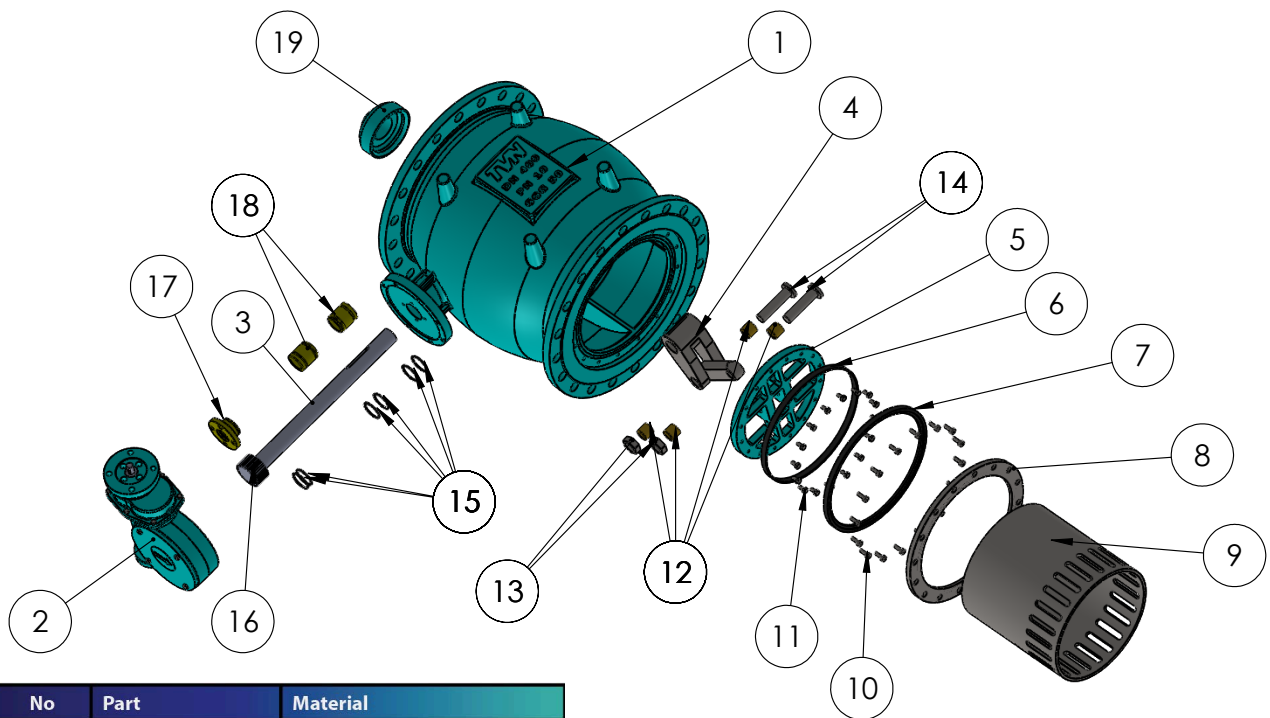

No	Part	Material
1	Body	Ductile Iron GGG50
2	Gear Box	Ductile Iron GGG50
3	Shaft	Stainless Steel AISI420
4	Crank & Connections	Stainless Steel AISI304-AISI316
5	Piston Connection	Ductile Iron GGG50
6	Piston Sealing	EPDM
7	Seat Sealing	EPDM
8	Seat Flange	Stainless Steel AISI304-AISI316
9	Piston	Stainless Steel AISI304-AISI316
10	Flange Fixings	Stainless Steel A2-A4
11	Piston Fixings	Stainless Steel A2-A4
12	Cranck Bush	Bronze
13	Cranck Nut	Stainless Steel A2-A4
14	Cranck Shaft	Stainless Steel AISI304-AISI316
15	O-Ring	EPDM
16	Gearbox Connection	Steel ST37
17	Sealing	Bronze
18	Dry Shaft Bush	Bronze
19	Back Cap	Ductile Iron GGG50

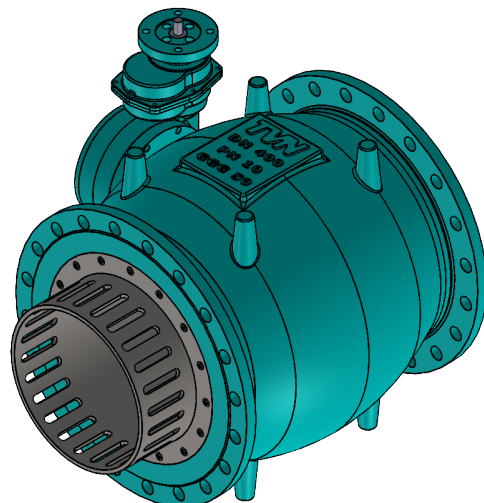

V901 PLUNGER / NEEDLE VALVE



Dimensions Table

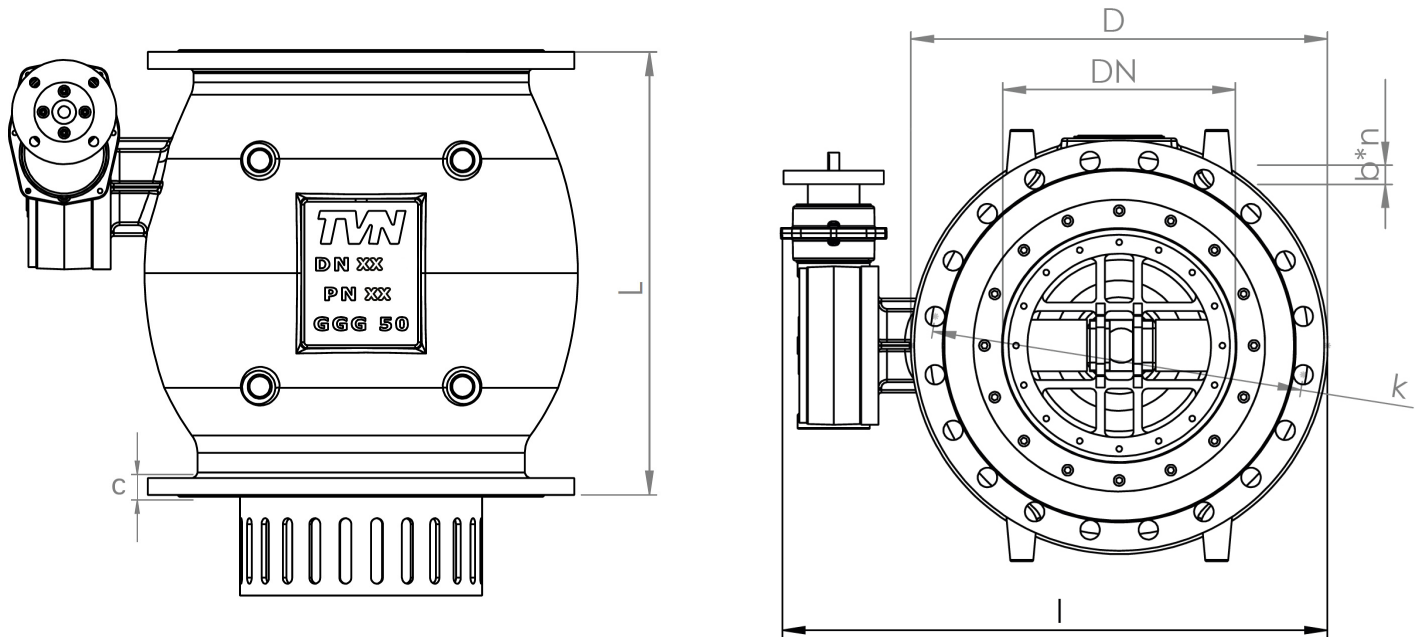

Nominal Diameter (DN)	PN10							Unit Weight (kg)	Torque
	L	l	D	k	b*n	c			
150	350	426	285	240	23*8	19	80	25	
200	400	485	340	295	23*8	20	115	30	
250	450	575	400	350	23*12	22	155	30	
300	500	683	455	400	23*12	24.5	190	35	
400	600	825	565	515	28*16	24.5	335	40	
500	750	962	670	620	28*20	26.5	590	50	
600	900	1095	780	725	31*20	30	1030	70	
700	1050	1235	895	840	31*24	32.5	1620	80	
800	1200	1335	1015	950	34*24	35	2050	80	
900	1350	1460	1115	1050	34*28	37.5	2750	90	
1000	1500	1610	1230	1160	37*28	40	4000	100	
1200	1800	1095	1455	1380	40*32	45	5300	105	

V901

PLUNGER / NEEDLE VALVE



Dimensions Table

Nominal Diameter	PN16							
	(DN)	L	I	D	k	b*n	c	Unit Weight (kg)
150	350	426	285	240	23*8	19	80	25
200	400	485	340	295	23*12	20	115	30
250	450	575	400	355	23*12	22	155	30
300	500	683	455	410	23*12	24.5	190	35
400	600	825	580	525	28*16	24.5	335	40
500	750	962	715	650	28*20	26.5	590	50
600	900	1095	840	770	31*20	30	1030	70
700	1050	1235	910	840	31*24	32.5	1620	80
800	1200	1335	1025	950	34*24	35	2050	80
900	1350	1460	1125	1050	34*28	37.5	2750	90
1000	1500	1610	1255	1170	37*28	40	4000	100
1200	1800	1095	1485	1390	40*32	45	5300	105

Nominal Diameter	PN25							
	(DN)	L	I	D	k	b*n	c	Unit Weight (kg)
150	350	426	300	250	28*8	20	80	PLEASE ASK
200	400	485	360	310	28*12	22	115	
250	450	575	425	370	31*12	24.5	165	
300	500	683	485	430	31*16	27.5	200	
400	600	825	620	550	37*16	32	370	
500	750	962	730	660	37*20	36.5	395	
600	900	1095	845	770	40*20	42	1110	
700	1050	1235	960	875	43*24	46.5	1820	
800	1200	1335	1085	990	49*24	51	2150	
900	1350	1460	1185	1090	49*28	59.5	2850	
1000	1500	1610	1320	1210	56*28	60	4250	
1200	1800	1095	1530	1420	56*32	74	5600	