

V551 FIRE HYDRANT



Product Description

Fire hydrants are the inevitable safety equipments in our daily lives that can be considered as one of the colleague of fire fighters in order to retrieve water from the main water line. It provides water to firefighting crew at any possible moment to act rapidly. They can be found widely around our living environment including factories, warehouses, industrial buildings, residential buildings, airports, harbors, military areas, parks and where there is fire risk. Above ground fire hydrants are easily reached when needed.



Technical Data	
Size range	DN80 - DN100
Height Range	1450 - 1750 - 2150mm
Pressure range	PN16
Temperature	-10°C to +80 °C
Design	EN 14384 / EN 1074-6
Connection Standard	EN 1092-2 / ISO 7005 - 2
Coating	Electrostatic Powder Epoxy
Testing	EN 12266-1
Marking	EN 19
Operation	Hydrant Key

Related Products

- V151 Resilient Seated NRS Gate Valve
- V304 Air Release Valve
- V556 N Part
- V557 Key



FIRE FIGHTING



POTABLE WATER

Product Features

- Due to their column shape and red color, it makes it visible and accesible incase of fire
- With the two water outlets(optionally three), large volumes of water can be retrieved in short time
- With its dry barrel construction, avoids freezing during operation through its inbuilt automatic drainage system
- The fire hydrant has a self-closing system to avoid water loss in case of break down and impact risk
- All inner and outer ductile iron surfaces and column pipes are coated with electrostatic powder epoxy where this coating material is of hygienic type
- It can be operated easily from the the valve located at the top of the hydrant
- Designed and manufactured according to EN 14384 standard
- Opens by rotating the hydrant clockwise and closes by rotating the hydrant anticlockwise
- With its key, easy to open and close
- DN80-DN100 sizes and 1,45 - 1,75 - 2,15mt. heights alternatives are available

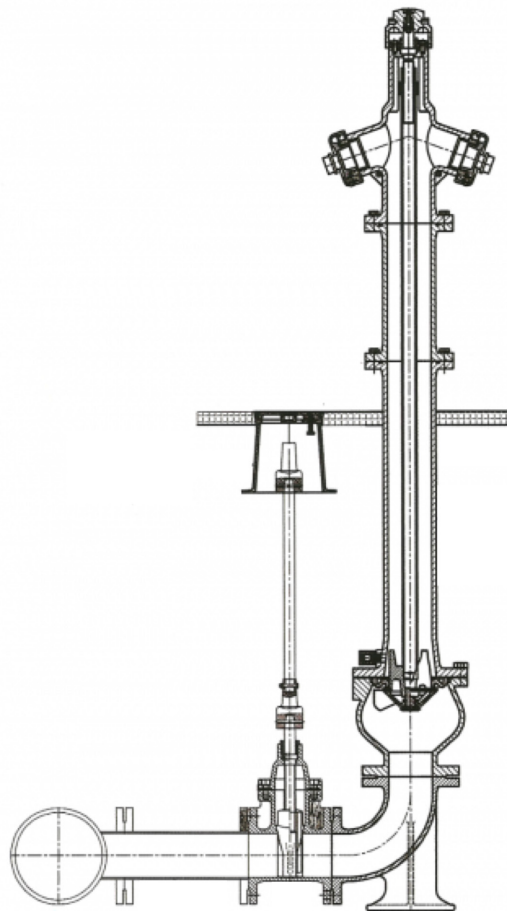

*System application.

V551

FIRE HYDRANT



Material List & Dimensions Table

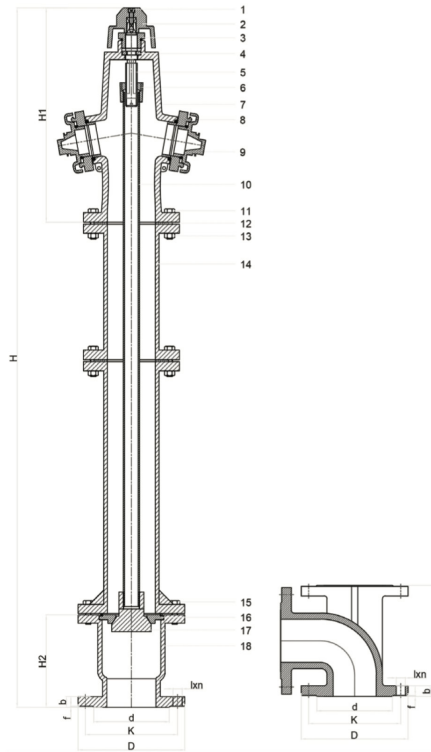

No	Item	Material
1	Bolt	Steel
2	Top Cover	Ductile Iron
3	Nut	Cast Iron
4	Circlip	Steel
5	Stem	AISI420
6	Pressure Nut	Cast Iron
7	Upper Body	Ductile Iron
8	Nut	Brass
9	Water Outlet	Brass /Aluminium
10	Operation Rod	Steel
11	Bolt	Steel
12	Sealing	EPDM
13	Nut	Steel
14	Middle Body	Ductile Iron
15	Bolt	Steel
16	Seat	Cast Iron
17	Closure element	Cast Iron
18	Lower Body	Ductile Iron

DN	H	D	K	d	øxn	f	b	L	H1	H2
80	1450	200	160	132	19x8	3	22	300	345	195
80	1750	200	160	132	19x8	3	22	300	345	195
80	2150	200	160	132	19x8	3	22	300	345	195
100	1450	220	180	156	19x8	3	24	300	345	195
100	1750	220	180	156	19x8	3	24	300	345	195
100	2150	220	180	156	19x8	3	24	300	345	195