

V103

LUG TYPE

BUTTERFLY VALVE



Product Description

TVN V103 Lug Type Butterfly valve construction is formed with the centered disc rotating inside the valve body 90 degrees. With the actuation type, the flow of the fluid can be stopped, regulated or started. In a lug connection, the valve is installed between the pipe flanges and tightened to its place with the full threaded bolts for the pipe flanges.

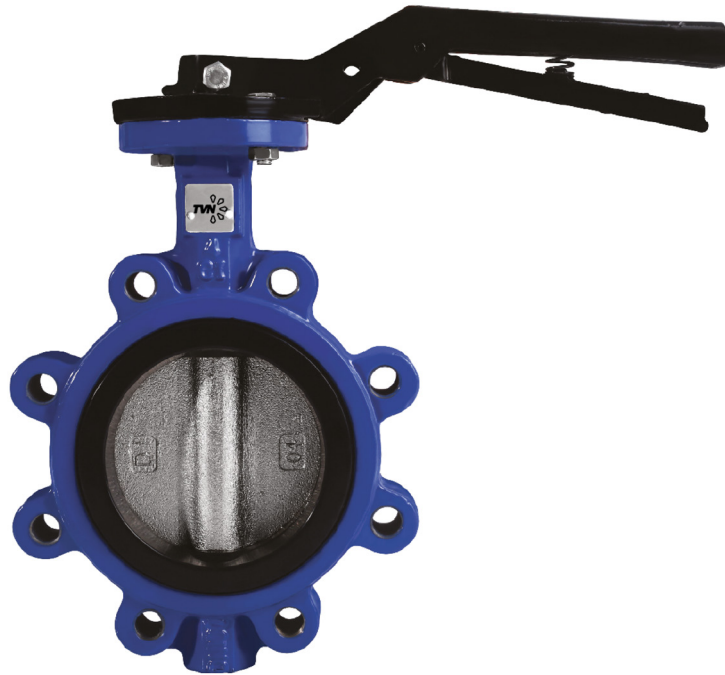

Technical Data	
Size range	DN40 - DN300
Pressure range	PN 16
Temperature:	EPDM : -10°C to +80 °C NBR - 10°C to + 60 °C VITON -10°C to + 120°C
Design	EN 593
Face to face	EN 558 Series 20 / ISO 5752 Series 20
Connection	Lug Type EN 1092-2 / ISO 7005-2
Coating	Electrostatic Powder Epoxy / Spray Epoxy
Testing	EN 12266-1
Marking	EN 19
Operation	Hand Lever
	Gearbox
	Pneumatic Actuator (Single/double acting)
	Electrical Actuator Quarter Turn/Modulating

Application Range

- HVAC Systems
- Pumping Stations
- Water Treatment Plants
- Reservoirs and Tanks
- Irrigation
- Industrial Applications

Related Products

- V208 Wafer Swing Check Valve
- V209 Dual Check Valve
- V851 Y-Strainer
- V651 Rubber Expansion Joint



V103

LUG TYPE

BUTTERFLY VALVE



Product Features

- V103 type is with Nickel Plated Ductile Iron Disc
- GG25 Cast Iron Body (GGG40 Ductile Iron is optional)
- EPDM sealing/sleeve/gasket is by default. Different sealing materials are available
- With its compact design saves space, light weight, easy to install and budget friendly
- Even the disc is located within the flow section, with the precisely calculated disc design pressure loss is kept at minimum level
- Machined disc ensures lower and regular torque
- Fully coated body avoids corrosion
- Standard version is with hand lever. With the intermediary lock positions on the lever, possible to fix the on desired position
- With ISO5211 top flange, direct mounting of gearbox, pneumatic or electric actuator is possible without any need for additional parts
- Bi-directional use, tight ealing in both ways
- Do not need any maintenance, easy to make spare part replacements
- Anti blow-out stem allows safety during operation
- No need for additional gaskets for installation on the pipeline
- With its long neck design, suitable for insulation application
- Can be used as an end of line valve for pipeline maintenance purposes
- Hydrostatic test pressure for seat: PN x 1.1 , for shell: PN x 1.5 according to EN 12266-1.

Material List

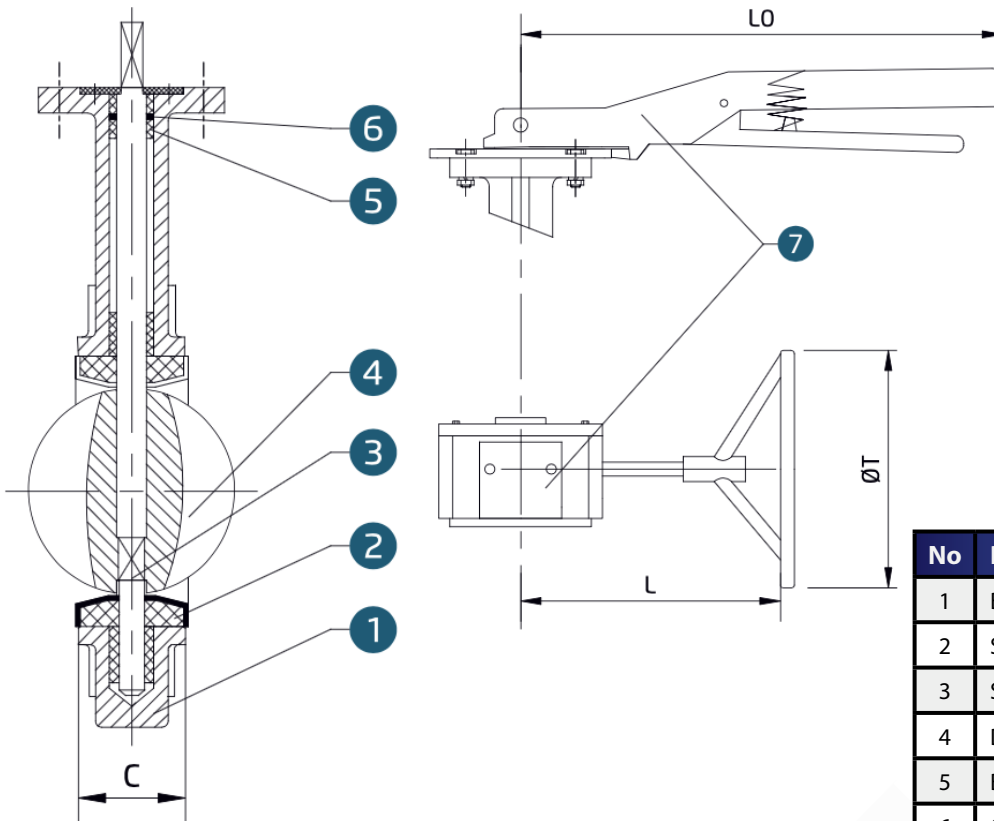

No	Part	Material
1	Body	GG25 / GGG40
2	Seat	EPDM / NBR / VITON
3	Stem	AISI 420 Stainless Steel
4	Disc	Nickel Plated DI
5	Bushing	PTFE
6	O-Ring	NBR/EPDM
7	Handlever	Aluminium

V103

LUG TYPE

BUTTERFLY VALVE



Dimensions Table

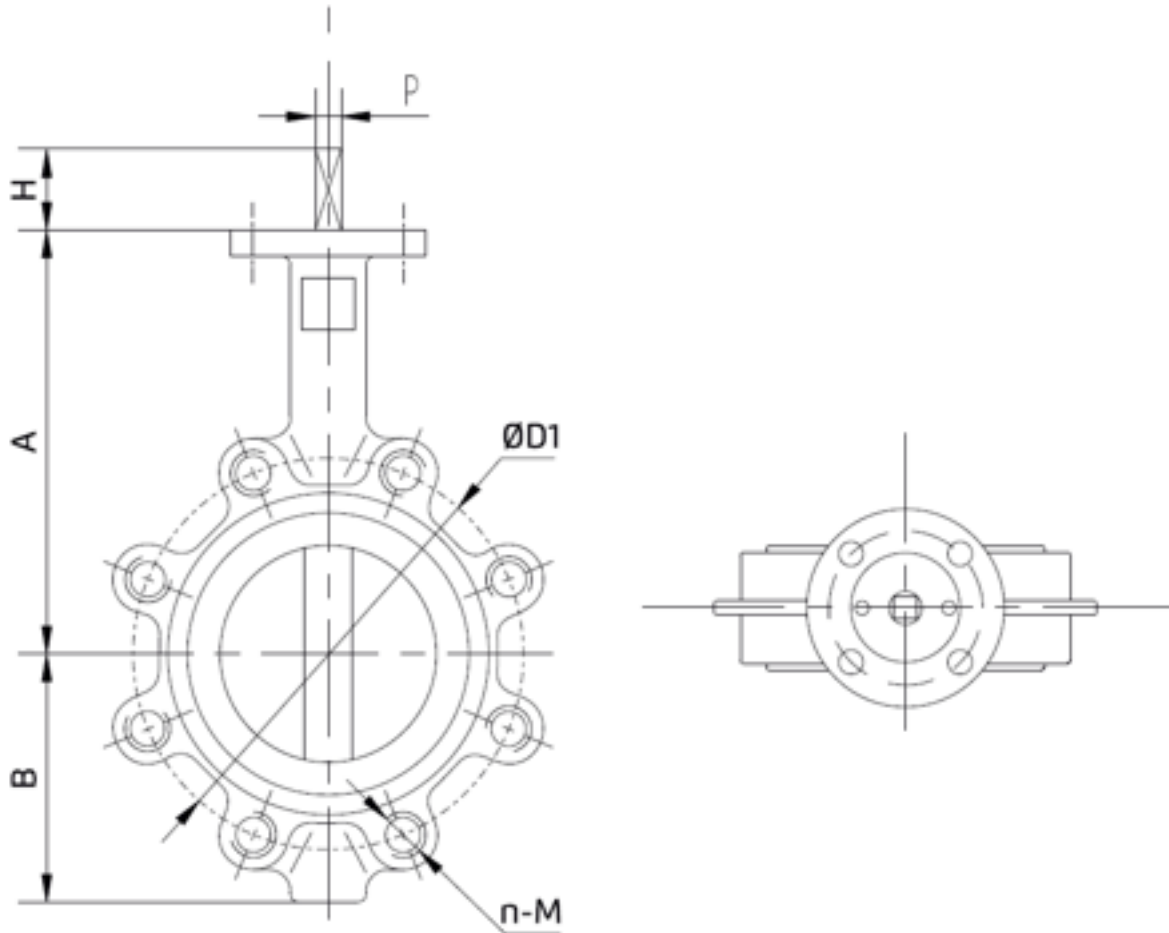

MM	A	B	H	P	C	Top Flange ISO 5211	LO	T	L	PN16	
40	125	68	30	9	33	F05	215	137	150	110	4-M16
50	129	73	30	9	42	F05	215	137	150	125	4-M16
65	137	82	30	9	44.7	F05	215	137	150	145	4-M16
80	144	95	30	9	45.2	F05	215	137	150	160	8-M16
100	163	109	30	11	52.1	F07	260	137	150	180	8-M16
125	179	125	30	14	54.4	F07	260	137	150	210	8-M16
150	198	144	30	14	55.8	F07	260	137	150	240	8-M20
200	237	173	35	17	60.6	F10	355	269	207	295	12-M20
250	281	211	35	22	65.6	F10	355	269	207	355	12-M24
300	318	244	35	22	76.9	F10	355	269	207	410	12-M24

ASSEMBLY INSTRUCTIONS

- 1- Move the two flanges with enough distance from the network so that the valve slides smoothly without damaging the lips of the elastic ring.
The butterfly will be in half-open position with no projection outside the valve width.
- 2- Centre the valve with the four screws/ties (two upper and two lower) without tightening them. Test the opening and closing of the butterfly to ensure its operation. Place the butterfly in perfectly centered position and open taking care not to damage its periphery. Tighten the screws/ties to fix the position of the BV.
- 3- Tighten the nuts until there is metal-metal contact between the body of the BV and the flanges of the network. Tighten the screws/ties "diagonally" and progressively. The tightening torque must be adequate to make metal-metal contact and less than the resistance capacity of the screw/tie.

Troubleshooting

Symptom	Possible cause	Resolution
Valve would not rotate	Actuator has failed	Replace or repair
Valve would not rotate	Valve packed with debris	Flush or clean valve to remove debris
Valve leaking	Valve not fully closed	Close valve
Valve leaking	Debris trapped in valve	Cycle and flush (with valve open) to remove debris
Valve leaking	Seat is damaged	Replace valve
Jerky operation	Debris trapped in valve	Cycle and flush (with valve open) to remove debris
Jerky operation	Air supply actuator inadequate	Increase air supply pressure and/or volume

Storage

When valves are to be stored for some time, (2 months or more) before being fitted, storage should be in the original delivery crates or cases.

Storage Conditions

The valves should be stored off the ground in a clean, dry indoor area. Protect the valve from temperature and humidity extremes, and exposure to excessive dust, moisture, vibration, deformations, sunlight and ozone.

Temperature: storage temperature below 25°C, above 0°C preferable below 15°C.

Humidity: storage conditions should be such that condensation does not occur, store in a dry environment. Maximal 50% relative humidity.

Light: valve rubbers should be protected from light, in particular direct sunlight or strong artificial light with high ultra violet.

Ozone: storage rooms should not contain any equipment generating ozone. E.g. lamps, electric motors.

Valve Installation

The valves are bi-directional and can be fitted in either direction relative to the flow. The valve will control flow equally in either direction. The recommended installation position is shaft horizontal and the lower disc edge opening downstream (especially for slurry service and media with a tendency for sedimentation). For optimum valve control and smooth performance, it is recommended to have 10 to 20 pipe diameters of straight run inlet piping and 3 to 5 pipe diameters straight outlet piping.

Do not use the valve as a crow-bar to spread the flanges, this might lead to damage to the flange area and/or damage to the O-ring sealing.